

J. M. PARKER.
GAGE-LATHE.

No. 171,696.

Patented Jan. 4, 1876.

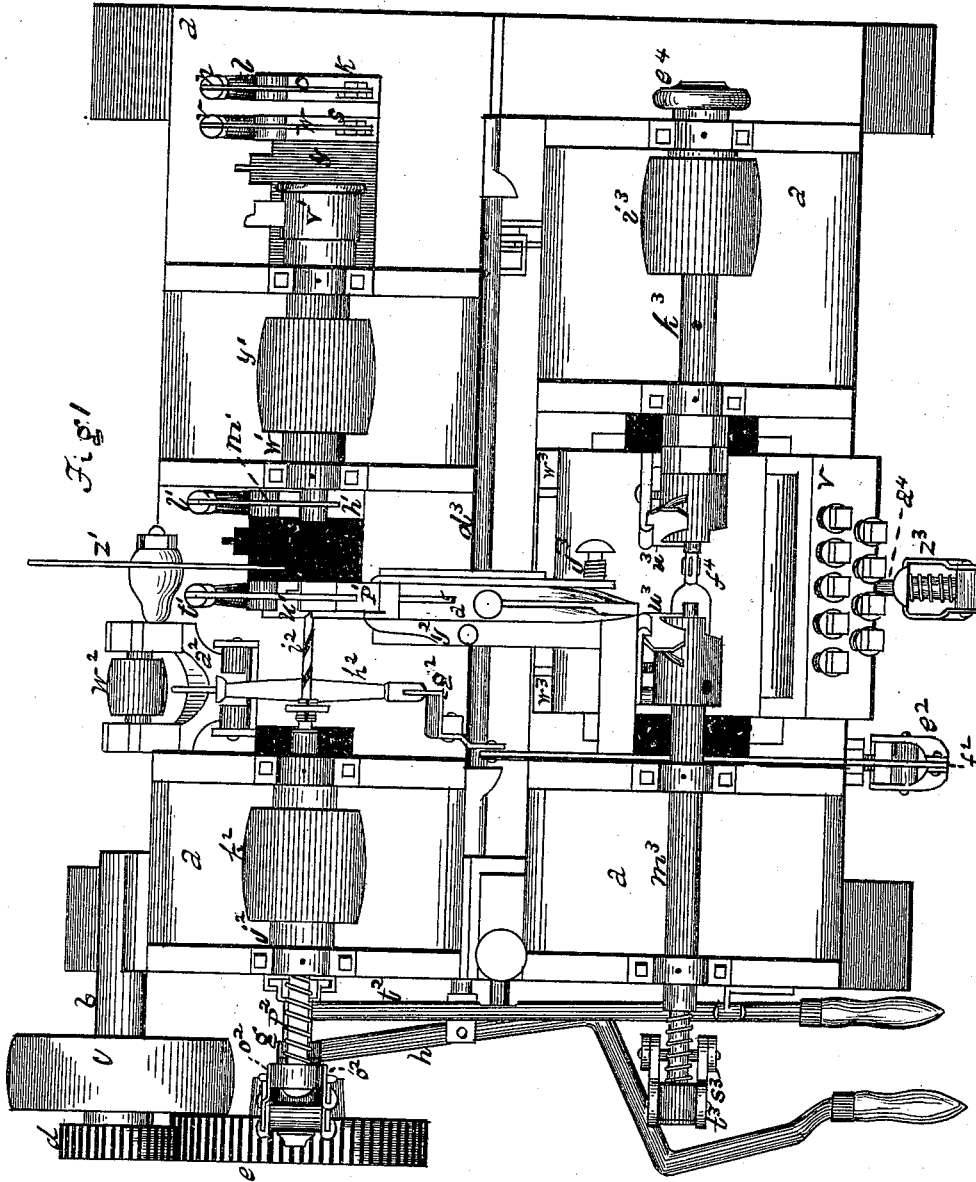

Fig. 1

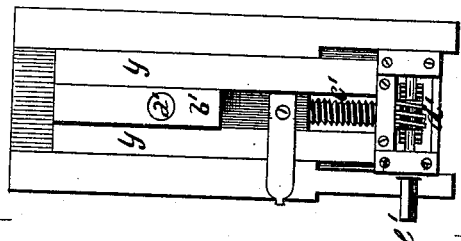

Fig. 7

Witnesses

John Pollitt
Francis G. Fuller

Inventor

John M. Parker
By W. E. Simonds
Att'y

J. M. PARKER.
GAGE-LATHE.

No. 171,696.

Patented Jan. 4, 1876.

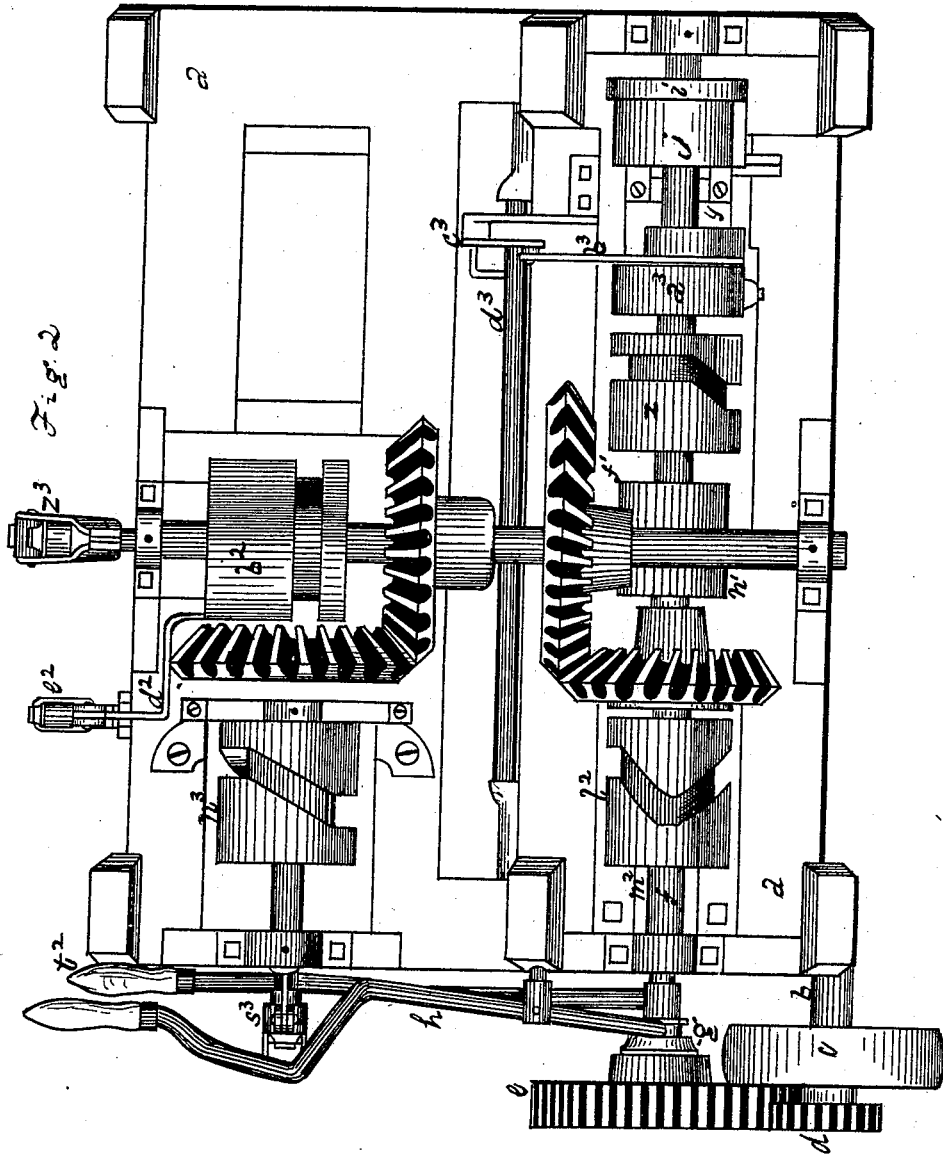

WITNESSES

John Pollard
Thomas G. Emerson

INVENTOR

John M. Parker
By *W. E. Simonds*
Atty

J. M. PARKER.
GAGE-LATHE.

No. 171,696.

Patented Jan. 4, 1876.

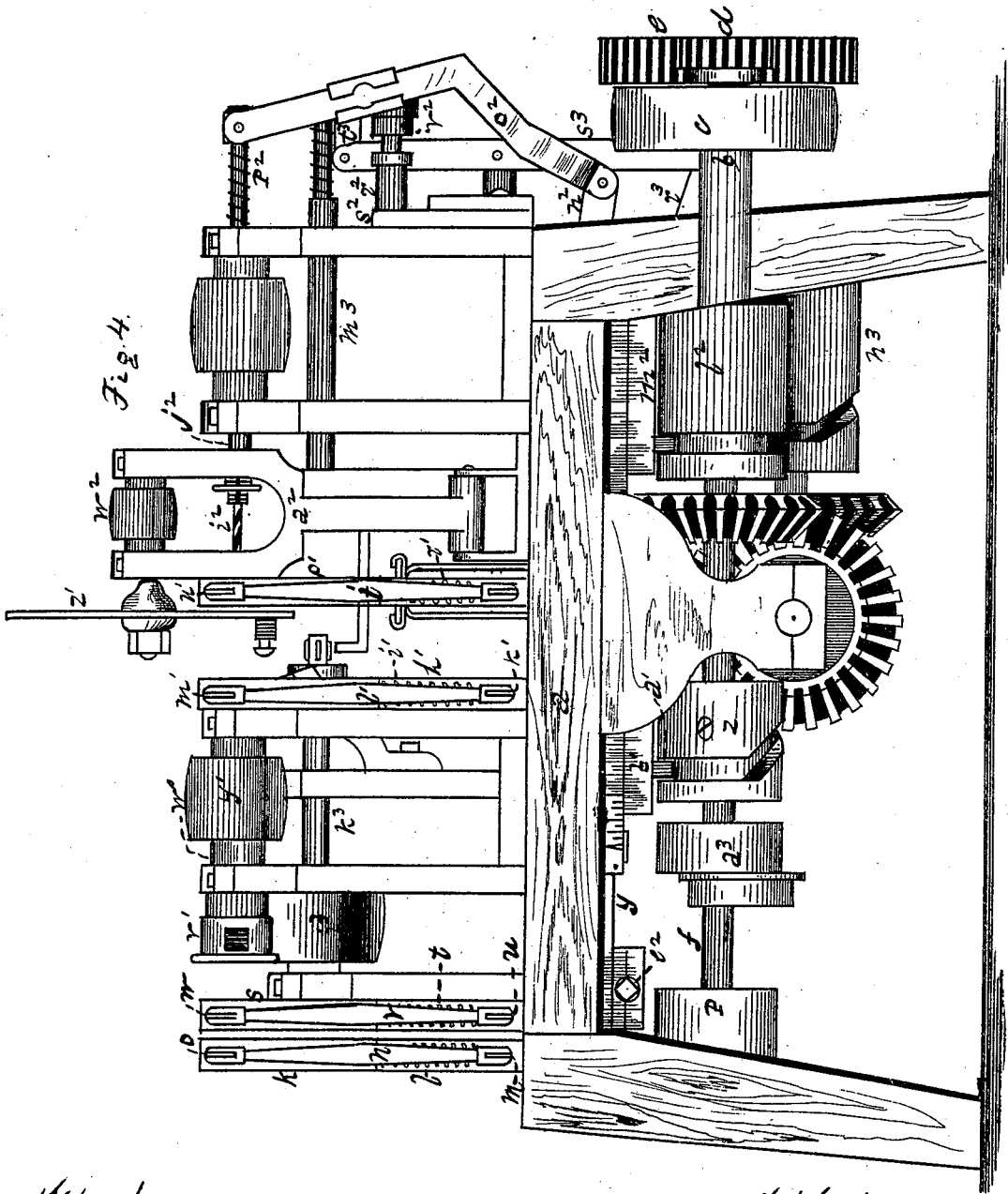

WITNESSES
 John Pollitt
 Frank G. Fuller

INVENTOR.
 John M. Parker
 By W. E. Simonds
 Atty

J. M. PARKER.
GAGE-LATHE.

No. 171,696.

Patented Jan. 4, 1876.

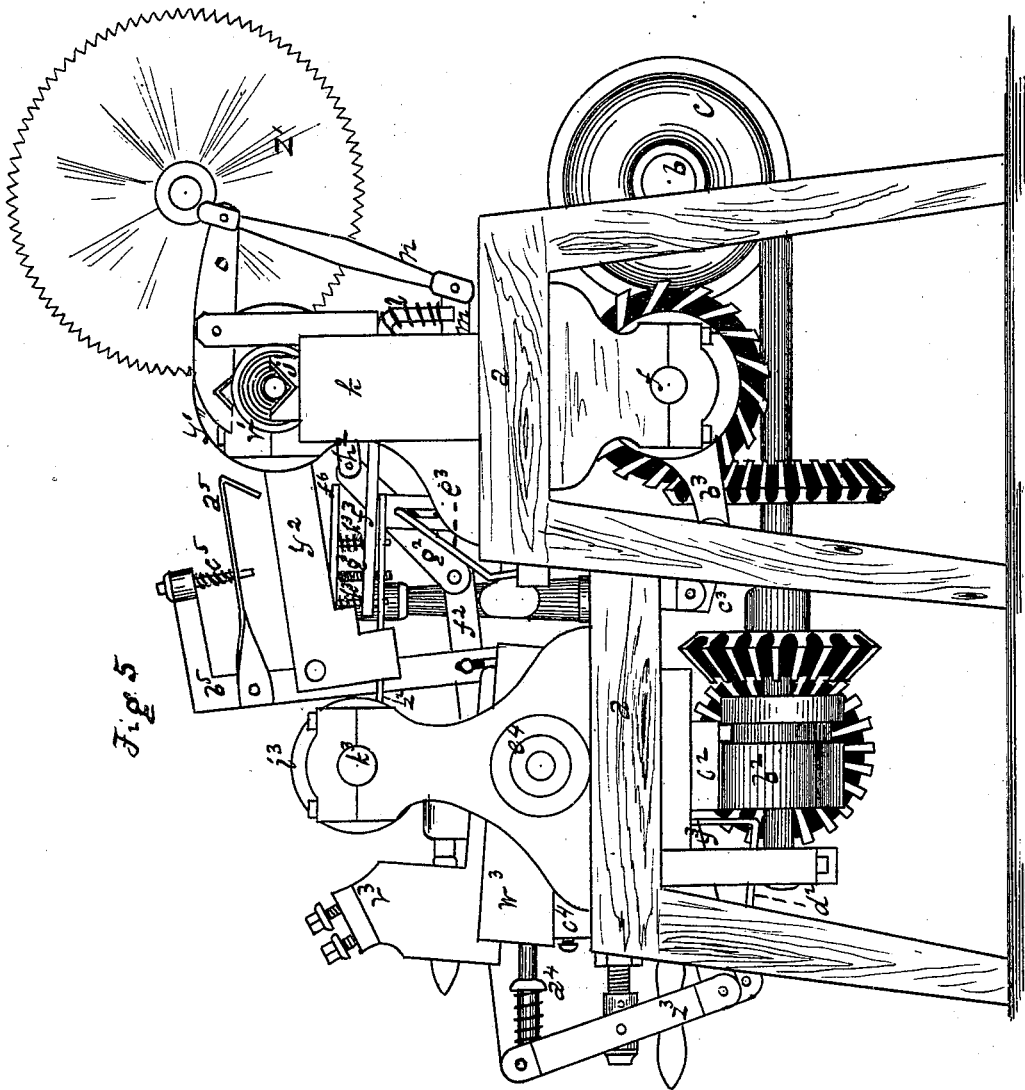

Fig. 5

WITNESSES.
John Pollitt
Samuel S. Green

INVENTOR.
John M. Parker
 By W. E. Simonds
 Atty.

J. M. PARKER.
GAGE-LATHE.

No. 171,696.

Patented Jan. 4, 1876.

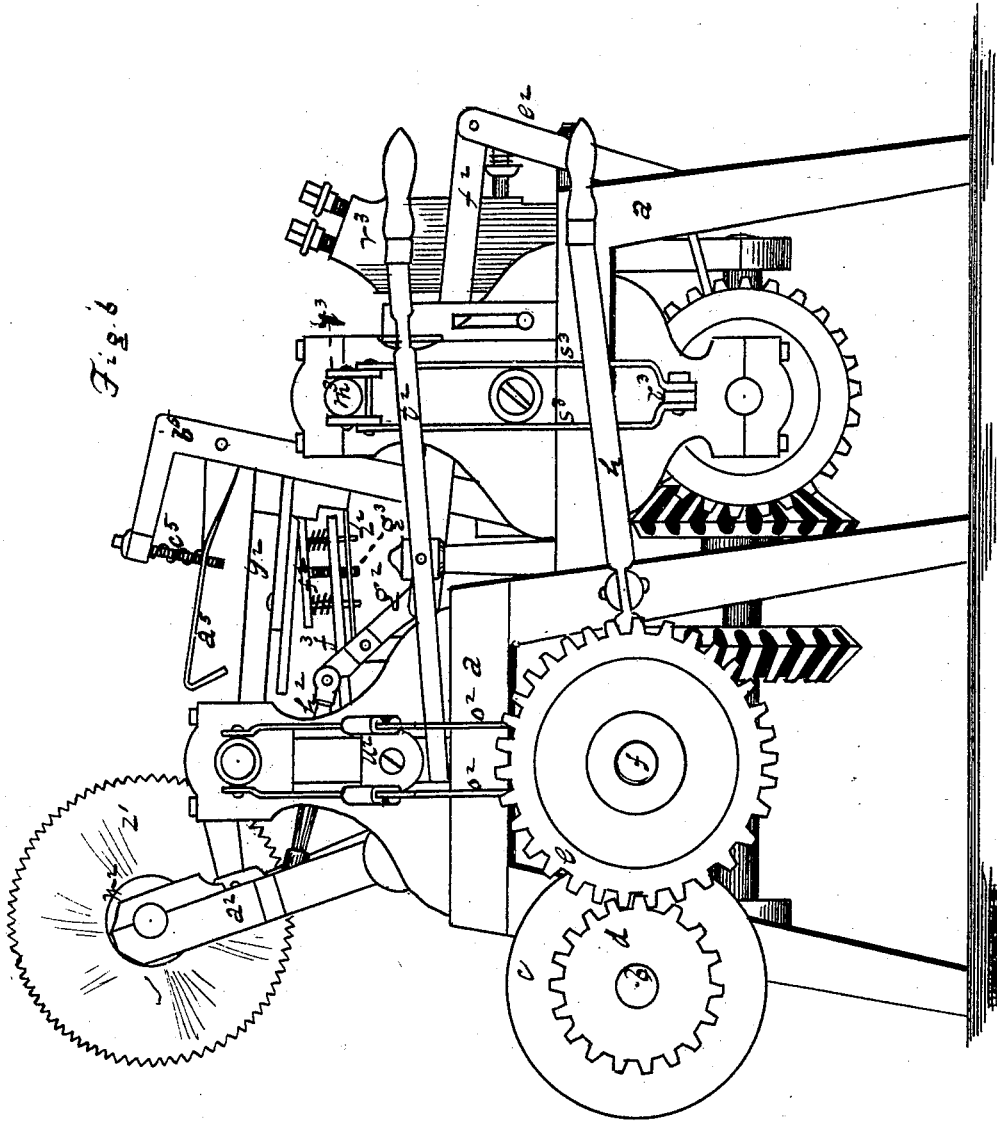

WITNESSES

John Pollitt
Francis L. Fuller

INVENTOR

John M. Parker
By W. E. Simonds
Atty

UNITED STATES PATENT OFFICE.

JOHN M. PARKER, OF SOUTH MANCHESTER, CONNECTICUT.

IMPROVEMENT IN GAGE-LATHES.

Specification forming part of Letters Patent No. 171,696, dated January 4, 1876; application filed July 2, 1875.

To all whom it may concern:

Be it known that I, JOHN M. PARKER, of South Manchester, in the county of Hartford and State of Connecticut, have invented an Improvement in Gage-Lathes, of which the following is a specification, reference being had to the accompanying drawings, where—

Figure 1 is a top view. Fig. 2 is a bottom view. Fig. 3 is a front view. Fig. 4 is a rear view. Fig. 5 is a right-end view. Fig. 6 is a left-end view. Fig. 7 is a detail view, showing the bottom or under side of the slide *y*, hereinafter specified and described.

The invention is a machine for automatically making wooden spools, such as thread is wound upon for sale in the stores. The wood is prepared by cutting into strips of proper size, square or rectangular in cross-section—though the shape in section is not essential—and this machine takes the stock in this shape and delivers it in finished spools.

I shall describe the parts and their operation, in the main, together.

The letter *a* denotes the frame; *b*, the power-shaft, which receives motion by a belt running upon the pulley *c* in the direction indicated by the overlying arrow, and the pinion *d* on this shaft gives motion to the gear *e*, which is loose on the main shaft *f*, which is thrown into or out of gear with the gear *e* by means of the clutch *g*, which is operated by the hand-lever *h*, on which main shaft is the cam *i*, which, at the proper time, pushes up the vertical jaw *j*, which moves in the stationary pillar *k*, its return movement given by the spring *l*, from the rear of which jaw *j* extends the arm *m*, pressed upon by the spring *l*, pivoted to the pitman *n*, the upper end of which is jointed to the rear end of the pivoted jaw *o*. On shaft *f* is also cam *p*, which, in a manner precisely similar to that just described, gives the opening and closing movements to the vertical jaw *r*—which moves in the sliding pillar *s*—the spring *t*, arm *u*, pitman *v*, and pivoted jaw *w*; but this set of jaws feeds the rough stuff, and has a back-and-forth sliding movement, as follows: The pillar *s* is set on the slide *y*, moving back and forth in ways in the frame or table, such movement being given by the cam *z* on shaft *f* into the cam-slot, of which the pin *a* projects from the bot-

tom of the slide *y*. The length of movement of the slide *y* is adjusted for feeding different lengths for different lengths of spools, as follows: The block *b*¹, from which the pin *a*¹ immediately proceeds, has some longitudinal play in, and independent of, the slide *y*, and the position of this block, relatively to the slide *y*, can be so adjusted by means of the screw *c*¹ bearing the worm-gear *d*¹ and the worm-shaft *e*¹, that the slide *y*, and consequently the pillar *s*, shall have the desired length of feeding movement. Over the main shaft are two more of these precisely similar clamping devices, as to one of which, *f*¹ denotes the cam, *g*¹ the vertical jaw, *h*¹ the stationary pillar, *i*¹ the spring, *k*¹ the rearward-extending arm, *l*¹ the pitman, and *m*¹ the pivoted jaw. The other of these last-mentioned clamping devices is also a feeder, and is set upon the slide *y*, and in it the letter *n*¹ denotes the cam, *o*¹ the vertical jaw, *p*¹ the sliding pillar, *r*¹ the spring, *s*¹ the rearward-extending arm, *t*¹ the pitman, and *w*¹ the pivoted jaw.

The letter *v*¹ denotes what is known in spool-making machines as the "rougner," from the fact that it roughly rounds the square stuff. It is hollow; has an inwardly-edged chisel or chisels; is set on the hollow shaft *w*¹, and is rotated by a belt running on the pulley *y*¹, in the direction indicated by the overlying arrow. The letter *z*¹ denotes a saw, for severing the roughly-rounded stuff into spool-lengths as it comes from the rougher. This saw is hung in the swinging arm *a*². Its forward and back movements given at the proper time by the cam *b*², into the cam-slot of which projects a pin from the reciprocating block *c*², connected to the saw-arm *a*² through the medium of the rod *d*², adjusting-lever *e*², pitman *f*², lever *g*², and pitman *h*². The auger-bit *i*², which drills the central holes in the spool-blanks, is set in the shaft *j*², which rotates with, but has longitudinal movement in, the pulley *k*². This bit is caused to advance to its work at the proper time by the cam *l*², which reciprocates the block *m*² by means of a pin running into its cam-slot from the block, and the block communicates longitudinal motion to the auger-bit shaft, through the agency of the pitman *n*², adjusting-lever *o*², and spring

p^2 , bearing against a shoulder on the auger-bit shaft, the purpose of the interposition of this spring being to not force the auger-bit forward with too much violence when it meets a knot or other obstruction. The movement of the auger-bit, to accommodate different lengths of spools, is regulated by means of the sliding fulcrum-post r^2 set in ways s^2 , and moved by the hand-lever t^2 , by means of which the fulcrum can be moved so far toward the auger-bit shaft as to give the shaft almost no longitudinal motion at all.

I have thus far mentioned two adjusting-levers. There are two more of them, and I will, at this point, describe their construction and use, taking the one last mentioned for illustration.

The lever is in two parts, o^2 o^2 , and they are pivoted on pins projecting from the sides of the fulcrum-block u^2 , which is borne between two collars on the screw-rod v^2 , which screws into the fulcrum-post r^2 , and by rotating this screw the fulcrum can be adjusted toward or from the fulcrum-post. Such adjustment is necessary in altering the length of play of the parts immediately affected. As the spool-blanks are severed by the saw z^1 , which is driven by a belt running on the pulley w^2 , they fall into the trough y^2 , and roll toward the front of the machine, and reaching the front end of the trough fall down, one by one, upon the feeder z^2 , which is reciprocated forward and back at appropriate times by the eccentric a^3 , communicating with the feeder through the rod b^3 , lever c^3 , rock-shaft d^3 , and arm e^3 , the feeder sliding in the ways f^3 . The feeder-top f^6 is adjustable vertically to fit different diameters of spool-blanks by means of the screw g^3 , the top and bottom of the feeder being kept apart by the springs h^3 , which allow the feeder to grasp the spool-blank under some pressure.

The pivoted gate i^3 keeps the spool-blanks from escaping accidentally at the front, it being pressed to vertical position by spring j^3 , and this spring allows the gate to give way to the front when the feeder moves forward with a spool-blank. This feeder takes the spool-blanks, one by one, and delivers them to the turning apparatus, which is composed in the main of the stationary rotating shaft k^3 , driven by belt in pulley l^3 , the sliding non-rotating shaft m^3 , and chisel apparatus, shortly to be described. The ends of the two shafts k^3 m^3 fit into the ends of the central hole in the spool-blank, the former having small lugs to cause the blank to rotate with the shaft. The shaft m^3 reciprocates automatically to receive and release the spool-blanks, its movements being given by the cam n^3 , block o^3 , bearing-pin p^3 , pitman r^3 , adjusting-lever s^3 , (for different lengths of spools,) and bent pitman t^3 . The end corners of the spools are chamfered by the chisels w^3 in the common manner, and the turning of the other parts is done by chisels set in the reciprocating chisel-rest v^3 in the common manner; but I operate

this chisel-rest automatically in a new manner. This chisel-rest reciprocates back and forth on the ways-block w^3 at the proper times, its movements being given by the cam b^2 , reciprocating block c^2 , pitman y^3 , adjusting-lever z^3 , (for different diameters of spools,) and the pitman a^4 , which takes hold upon the pivot-shaft b^4 , made long, as shown, to permit the sidewise adjustment of the chisel-rest and the ways-block which carries it, this ways-block having such sidewise adjustment upon the ways-block c^4 , the pins d^4 d^4 keeping the pitman a^4 always in proper line. The sidewise adjustment of the chisel-rest and the ways-block w^3 is given by means of the adjusting-screw e^4 . The hook f^4 , attached to the shaft m^3 , pulls the finished spool off the end of the shaft k^3 when the spool is finished, and the shaft m^3 moves back, and then the spool falls down out of the way.

The operation of the parts is as follows: The square stuff is run through the rougher v^1 , being fed by the second set of feeding jaws r w , the jaws j o holding the stuff stationary, while the jaws r w are retreating. The stuff comes out at the opposite end of the hollow rougher-shaft w^1 rounded. Here the third set of feeding jaws o^1 w^1 feeds the stuff for the saw and auger-bit, the fourth set of jaws, g^1 m^1 , holding the stuff when the jaws o^1 w^1 are retreating. Now, the auger-bit z^2 bores the central hole, the saw z^1 swings forward and cuts off a spool-blank, which falls into the trough y^2 , runs down to the front end of the trough, and falls on the feeder z^2 , which advances and gives the blank to the turning-shafts, the shaft m^3 closing endwise on the blank for that purpose. Now the chisels in the chisel-rest v^3 advance and turn the spool, the shaft m^3 retreats, the hook f^4 knocks off the spool, and it is finished.

After the saw has severed a spool-blank from the roughed stuff, the hooked lever a^5 , pivoted by its rear end to the lever b^5 , which is pivoted at its foot and caused to swing in proper times by pivoting to the pitman f^2 , the movements of which have been described, and said hooked lever a^5 being pressed down by spring c^5 , moves rearward at the proper time, its hook takes hold upon the freshly-severed spool-blank and pulls it forward into the trough y^2 .

I claim as my invention—

1. The combination of the jaw j with arm m , the pitman n , and jaw o , all operating substantially as shown and described.
2. The combination of the cam p , jaw r , pillar s , pitman v , jaw w , and the slide y with the rougher v^1 , all operating substantially as shown and described.
3. The combination of the slide y , cam z , pin a^1 , block b^1 , screw c^1 , bearing worm-gear, and worm-shaft e , all operating substantially as shown and described.
4. In combination, the rougher v^1 , with its hollow shaft, the saw z^1 , arranged to reciprocate at the end of said hollow shaft, and the

auger-bit i^2 , arranged to bore the stock while protruding from said hollow shaft, all substantially as described.

5. The combination of the auger-bit i^2 , shaft j^2 , spring p^2 , adjusting-lever o^2 , pitman n^2 , cam-block m^2 , and cam l^2 , all arranged to operate substantially as shown and described.

6. The combination of the lever o^2 , fulcrum-block u^2 , screw v^2 , and fulcrum-post r^2 , all arranged to operate substantially as shown and described.

7. In combination, the rougher v^1 , with its hollow shaft, the saw z^1 , arranged to reciprocate in front of the end of said hollow shaft,

and the inclined trough y^2 , arranged to receive the blanks as sawed off and convey them away by gravity, all substantially as described.

8. The combination of the feeder z^2 , feeder-top f^6 , screw g^3 , and springs h^3 , all arranged substantially as shown and described.

9. The combination of the hooked lever a^5 , lever b^5 , and spring c^5 , all operating substantially as shown and described.

JOHN M. PARKER.

Witnesses:

C. E. BENTON,
O. P. WILKES.